

J. LEWIS.
MACHINE FOR CUTTING VENEER.

(Application filed Apr. 20, 1900.)

(No Model.)

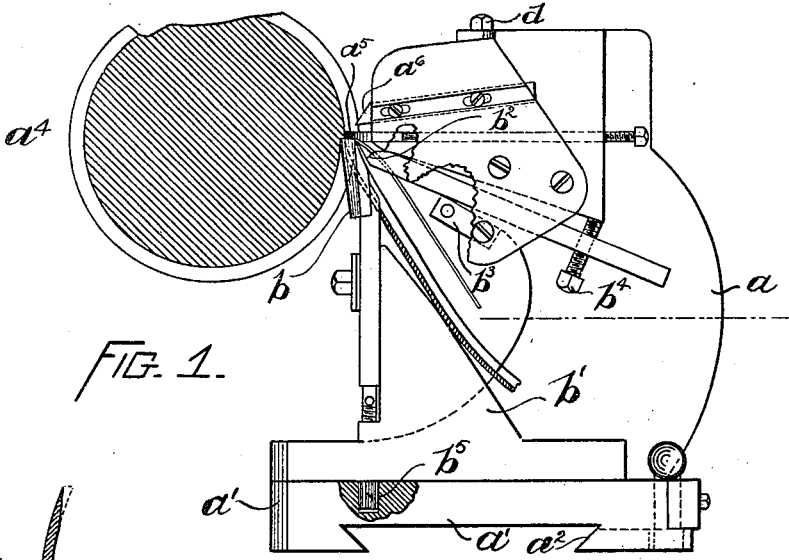

FIG. 1.

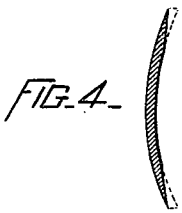

FIG. 4.

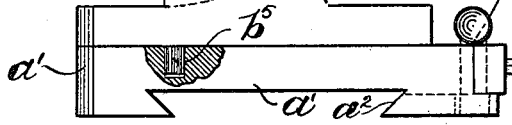

FIG. 2.

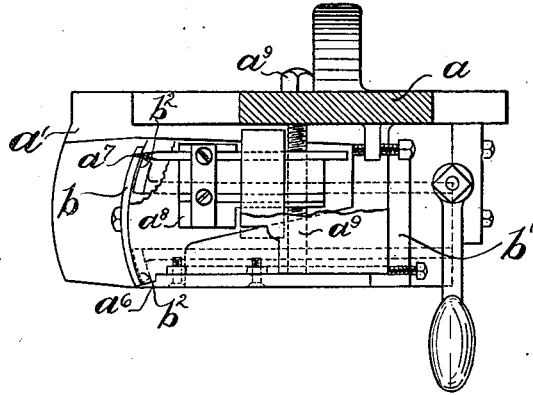

FIG. 3.

WITNESSES.
Philip H. Coombs
W. E. Southard

INVENTOR.
John Lewis
By his Attorney
Harry O. Robinson.

UNITED STATES PATENT OFFICE.

JOHN LEWIS, OF BROWNVILLE, MAINE, ASSIGNOR OF ONE-HALF TO GEORGE
E. M. LEWIS, OF TRURO, CANADA.

MACHINE FOR CUTTING VENEER.

SPECIFICATION forming part of Letters Patent No. 663,450, dated December 11, 1900.

Application filed April 20, 1900. Serial No. 13,576. (No model.)

To all whom it may concern:

Be it known that I, JOHN LEWIS, a subject of the Queen of Great Britain, and a resident of Brownville, Piscataquis county, State of Maine, have invented certain new and useful Improvements in Machines for Cutting Veneer, of which the following is a specification.

This invention relates to a machine for cutting veneer in which a bolt of wood is revolved in continuous contact with cutting-knives, whereby a connected thin spiral sheet is severed from the revolving bolt, and particularly to that class of machines adapted to sever a curved strip or ribbon of veneer having chamfered or beveled ends.

The objects of this invention are to provide improved means for adjusting the curved knife to sever sheets or ribbons of veneer of different widths from the bolt of wood, to provide means for adjusting the cutting-off knives laterally to different widths of veneer to be severed by said curved knife, and to provide improved means for securing the chamfering-knives in the knife-head.

In accordance with this invention a frame or casting forming the knife-head is provided, having a bed-plate adapted to support a holder for the curved knife, and said holder is pivoted to said casting and arranged to swing or turn upon said bed-plate to adjust said curved knife substantially parallel to the bolt of wood to sever a ribbon of veneer of the required width, and means is provided to secure said curved knife-holder to said bed-plate. A threaded bolt or screw is arranged in said casting to move a block carrying one of the knives for cutting off the ends of the ribbon of veneer, to adjust said knives to the width of the ribbon of veneer severed by said curved knife, and a bar secured to said casting is provided and arranged substantially at right angles to the chamfering-knives, and thereby secure said chamfering-knives between said casting and said bar, as will be explained.

Figure 1 of the drawings is a side elevation of the knife-head with all its parts in position. Fig. 2 is a plan view of the parts shown in Fig. 1 with a part of the knife-head casting broken away to fully expose the parts un-

derneath. Fig. 3 is a plan view of the curved knife-holder with a part of the casting of the knife-head removed, showing means for adjusting the curved knife substantially parallel to the bolt of wood. Fig. 4 is a cross-section of the ribbon of veneer, showing in dotted lines that portion of the veneer cut away by the chamfering-knives.

The casting a forms the knife-head of the machine, as shown in side elevation in Fig. 1, having a bed-plate a' , with a guideway a^2 formed therein adapted to engage a part of the bed-plate of the lathe in which the bolt of wood is revolved. (Not shown in the drawings.) Said knife-head is adapted to be adjusted along said bed-plate of the lathe, and a cross-feeding device (not shown in the drawings) is provided to move said knife-head into continuous contact with a bolt of wood a^4 to sever therefrom a continuous ribbon of veneer. The casting a projects upwardly, having a cavity in its upper end, in which a presser-bar a^5 and cutting-off knives a^6 and a^7 are secured, one of said cutting-off knives a^6 being secured to said casting a and the other knife being arranged in a block a^8 , supported in said casting a , and movable laterally therein to vary or change the width of the ribbon of veneer. To move said block a^8 , carrying said cutting-off knife a^7 laterally, a threaded bolt or screw a^9 is provided, passing laterally through the sides of said casting a and through said block a^8 , carrying said cutting-off knife a^7 , so that by turning said screw a^9 said block a^8 and knife a^7 , secured therein, may be moved laterally to vary the width of the space between said knives a^6 and a^7 , and one or more bolts d are arranged to pass down through the upper end of said casting a to securely hold said knife-block a^8 and presser-bar a^5 in place, as shown in Figs. 1 and 2 of the drawings.

The curved knife b for cutting a spiral sheet of veneer from the revolving bolt of wood a^4 is arranged in a knife-holder b' , supported upon the bed-plate a' , formed in said casting a , and said knife-holder b' is pivoted to said bed-plate a' and arranged to swing or turn thereon to adjust said curved knife b to a position substantially parallel to the bolt of wood a^4 , so that a ribbon of veneer of

any required width may be severed therefrom. The curved knife b may be of a size to sever a ribbon of veneer of the greatest width required, and when it is desirable to sever a ribbon of veneer of lesser width the knife-holder b' may be adjusted to move said curved knife b into a position substantially parallel to the bolt of wood a^4 to sever a ribbon of veneer of the required width, so that the chord of the arc upon which the knife is curved will be substantially parallel to the grain of the bolt of wood, and said knife-holder b' will be clamped or secured in position, which is carried out by pivoting said knife-holder b' , carrying said curved knife b to said bed-plate a' of said casting a upon which said knife-holder b is supported, a pin b^5 , formed in said knife-holder b' , entering a socket formed in said bed-plate a' , and to secure said knife-holder b' in place after adjustment has been made radial slots b^6 are formed therein and bolts b^7 or threaded studs pass up through said slots b^6 , having nuts b^8 , adapted to secure said knife-holder b' to said casting a , as shown in Fig. 3 of the drawings.

The curved knife is adapted to sever a curved ribbon of veneer of uniform thickness, and to chamfer or bevel the ends thereof chamfering-knives b^2 are arranged in said casting a , forming the knife-head, which sever a strip from each end of the curved ribbon of veneer, thereby forming a ribbon of cross-section substantially as shown in Fig. 4, the dotted lines indicating that portion of the ribbon cut away by the chamfering-knives. To securely hold said chamfering-knives b^2 in said knife-head a , so that they may be quickly adjusted to different widths of veneer to be severed from the bolt of wood or be removed and others substituted, a bar b^3 is arranged laterally in said casting a , having opposite ends secured thereto, as shown in Fig. 1, and extending substantially at right angles to the chamfering-knives b^2 , form-

ing a narrow space between itself and the upper part of said casting a . To secure said chamfering-knives b^2 in position, a bolt b^4 is arranged to pass through a threaded hole formed in the shank of both of said chamfering-knives b^2 and bear against said casting a , the shanks of said chamfering-knives b^2 passing through the space between said bar b^3 and said casting a , so that by turning said bolts said shanks will be cramped and pressed against said casting a , forming the knife-head, and said bar b^3 , as shown in Fig. 1 of the drawings, securely holding said chamfering-knives b^2 in position to engage the ribbon of veneer.

I claim—

1. In a machine for cutting veneer, a knife-holder carrying a knife, the edge of which runs in the direction of the axis of the log, said knife-holder pivoted adjustably on an axis at right angles to the axis of the log and to the direction of feed toward the log, and means for securing the knife-holder in its adjusted position, substantially as described.

2. In a machine for cutting veneer, a knife-head, a bar carried thereby, and a chamfering-knife provided with a screw adapted to engage the knife-head and clamp the knife between the knife-head and said bar, substantially as described.

3. In a machine for cutting veneer, a knife-head, a bar carried thereby, and a chamfering-knife provided with means for causing the upper and lower surfaces of the knife to impinge at different points against the knife-head and bar respectively, thereby clamping the knife in position, substantially as described.

Signed by me at Bangor, Maine, this 18th day of April, 1900.

JOHN LEWIS.

Witnesses:

WM. B. PEIRCE,
HARRY O. ROBINSON.